

SBA-118

Sub-Bass Series



EXPERIENCE THE SOUND
OF TRUE ENGAGEMENT

Arrayable High Output Sub-Bass

DESCRIPTION

The **SBA-118** employs a 18-inch long-excursion driver in an optimally tuned vented enclosure. It is an ideal choice for applications requiring precise transient response and low bass extension in a compact very high output package.

The **SBA-118** is frequently used as a single unit, or in multiples to create cardioid bass arrays. Its compact size fits well under stages or on stage, and dimensionally matches the HLA-20 in flown arrays.



KEY FEATURES

- Compact size
- Bass extension to 27 Hz
- Very high output
- Excellent transient response
- Component of Cardioid Bass Arrays

APPLICATIONS

- Churches
- Performing Arts Centers
- Cinema
- Night Clubs
-

DESCRIPTIVE DATA

System Configuration:	Dedicated sub-bass
Components & Loading:	(1) 18" long-excursion cone driver
Recommended High-Pass Filter:	4 th order Butterworth @ 24 Hz
Input Connectors:	(3) NL-4
Enclosure Type:	Optimally tuned, vented
Enclosure Material:	Hardwood multi-ply plywood
Finish:	Black or White standard (custom colors available)
Suspension Hardware:	(12) 3/8-16 threaded mounting points located on enclosure sides
Grille:	Painted perforated steel

NOMINAL DATA

Frequency Response:	27 – 350 Hz \pm 3 dB
Sensitivity:	97 dB @ 2.83 volts / 1M (in operating band)
Impedance:	8 Ω
Power Handling:	1600 W long-term (AES-2)
Maximum Long-Term Output:	129 dB @ 1M
Peak Output:	135 dB @ 1M
Nominal Coverage Angles:	Omni-directional
Dimensions	Height: 19.77" / 502 mm
	Width: 21.15" / 537 mm
	Depth: 30.68" / 779 mm
Net Weight:	102 lbs / 46.4 kg
Shipping Weight:	127 lbs / 57.7 kg

SBA-118

Sub-Bass Series



EXPERIENCE THE SOUND
OF TRUE ENGAGEMENT

DIMENSIONAL DRAWINGS

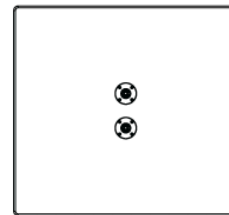
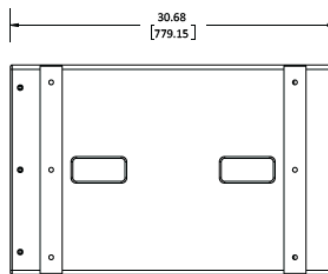
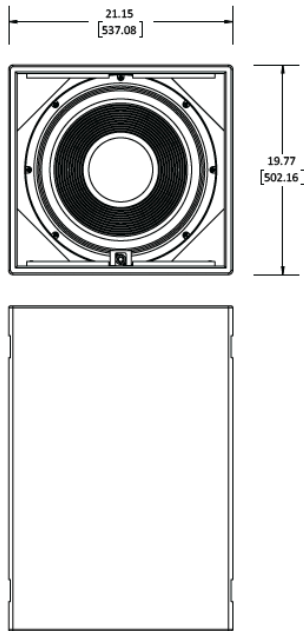

Optional Accessory

HLA SBA-20 F/B

The HLA SBA-20 F/B suspension system hangs an SBA-118 cardioid sub-bass array behind an HLA-20 Hybrid Line Array. It provides a compact solution where vertical height is limited.

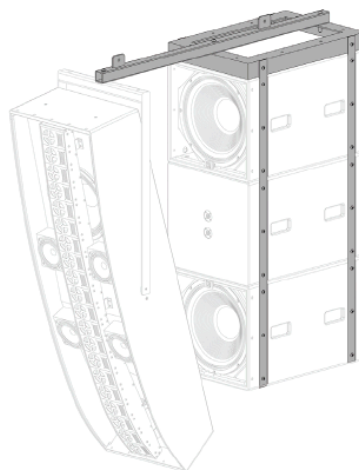

HLA SBA-16 T/B

The HLA SBA-16 T/B suspension system hangs an HLA-16 below an SBA-115 cardioid sub-bass array. It provides a compact solution where depth is limited.

